

## Thank you

---

Thank you for purchasing the **tesuñho**<sup>®</sup> TH-288 walkie talkie .  
This walkie talkie is designed for those who require top-grade quality, solid performances and outstanding reliability under the most demanding conditions.  
We encourage you to read this manual thoroughly, so as to learn about the many exciting features of your new walkie talkie.

### **WARNING**

- Government law prohibits the operation of unlicensed walkie talkie within the territories under government control.
- Illegal operation is punishable by fine or imprisonment or both.
- Any adjustment to your walkie talkie must be made by qualified technicians.

## PRECAUTIONS

- Refer service to qualified technicians only.
- Do not modify or attempt to adjust this walkie talkie for any reason.
- Do not expose the walkie talkie to long periods of direct sunlight, nor place it close to heating appliances.
- Do not operate the walkie talkie or charge a battery pack in an explosive atmosphere (gases, dust, fumes, etc).
- Do not place the walkie talkie in excessively dusty, wet areas, nor on unstable surfaces.
- Do not transmit with high output power for extended periods. The walkie talkie may overheat.
- Do not transmit until all RF connectors are secure and any open connectors are properly terminated.

  
CAUTION

- ▲ It is important that the operator is aware of, and understands hazards common to the operation of any walkie talkie. Turn off the walkie talkie while taking on fuel or while parked in gasoline service.
- ▲ If an abnormal odor or smoke is detected coming from the walkie talkie, switch OFF the power immediately and remove the battery pack from the walkie talkie. Contact your authorized **tesunho** dealer, customer service, or service station.



## CONTENTS

<b>UNPACKING AND CHECKING EQUIPMENT</b>	1-2
<b>PREPARATION</b>	3-9
CHARGING Li-ion BATTERY PACK	3-4
INSTALLING/REMOVING BATTERY PACK	5-6
INSTALLING ANTENNA	6
INSTALLING BELT CLIP	7
INSTALLING SPEAKER/MICROPHONE COVER	7
INSTALLING EXTERNAL SPEAKER/MICROPHONE	8
INSTALLING UIM CARD	9
<b>GETTING ACQUAINTED</b>	10-13
<b>BASIC OPERATION</b>	14-18
POWER ON	14

TRANSMITTING	15
RECEIVING	16
GROUP SWITCHING	16
SELECTIVE CALL	17-18
<b>ADVANCED FUNCTIONS</b>	19-20
USER RIGHTS SETTING	19
INTERRUPT PRIORITY	19
DEFINITION OF PROGRAMMABLE FUNCTION KEY	19
LED FLASHLIGHT FUNCTION	20
TIME-OUT TIMER (TOT FUNCTION)	20
<b>TROUBLESHOOTING GUIDE</b>	21
<b>AFTERSALES SERVICES</b>	22



## 01 UNPACKING AND CHECKING EQUIPMENT

Carefully unpack the walkie talkie. We recommend that you identify the items listed in the following table before discarding the packing material. If any items are missing or have been damaged during shipment, file a claim with the carrier immediately.

Supplied accessories	ITEM	QUANTITY
	Antenna	1
	Li-ion battery pack	1
	Intelligent charger	1
	AC power adaptor	1
	Belt clip	1
	User's manual	1

Optional accessories	ITEM
	Headset
	Programming cable & software
	Speaker / microphone
	USB charger cable

### Standard Accessories:

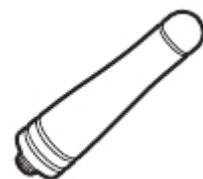

Antenna



Battery pack



Intelligent charger



AC power adaptor



Belt clip

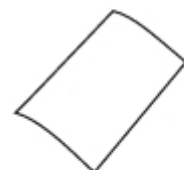

User's manual

### Optional Accessories:



Headset



USB programming cable



Speaker/Microphone



USB charger cable

① **Charging Li-ion battery pack**

The Li-ion battery pack is provided uncharged at the factory for safety purposes. Please charge them before use. It takes approximately 8 hours to charge an empty Li-ion battery pack. Initially charging the battery pack after purchase or extended storage (longer than 2 months) will not bring the battery pack to its normal operating capacity. After repeating the charge/discharge cycle two or three times, the operating capacity will increase to normal.

CAUTION

- ▲ Please only use the **tesunho**® supplied battery and charger. Or it may cause the life of the battery pack to shorten or the battery pack may be damaged.
- ▲ Exceeding the specified charge period shortens the useful life of the Li-ion battery pack.
- ▲ The battery pack life is over when its operating time decreases even though it is fully and correctly charged. Replace the battery pack.
- ▲ The battery pack must be kept in cool and dry place. Never leave the battery pack in the direct sunlight.

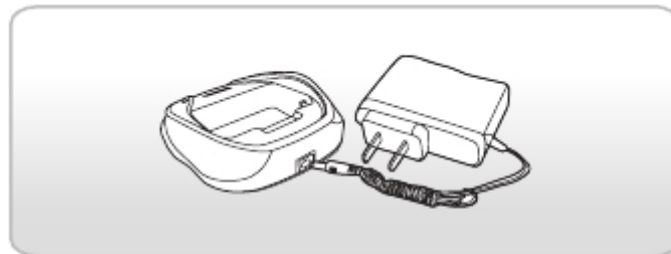
● **Connecting to an intelligent charger**

1. Plug the AC adapter cable into the adapter jack located on the rear of the charger.
2. Plug the AC adapter into AC outlet.
3. Insert the battery pack or walkie talkie with the battery pack into the intelligent charger.
  - \* When charging begins, the LED on the charger lights RED.
  - \* While charging, the green LED on the charger flashes.
  - \* When the green LED on the charger turns on, it is fully charged.
4. When charging completes, unplug the AC plug from the power outlet.



## ② Installing/removing battery pack

The average life of the supplied Li-ion battery pack is 9 hours. Average times are calculated by using 5% transmit time, 5% receive time, and 90% standby time.

### NOTE

- ▲ Do not short the battery terminals or dispose of the battery by fire.
- ▲ Never attempt to remove the casing from the battery pack.

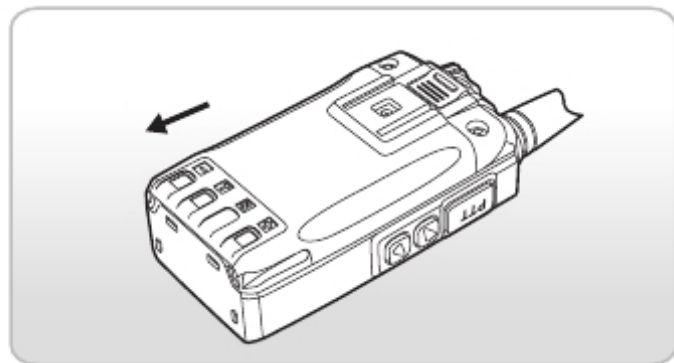

1. Match the grooves of the battery pack with the corresponding guides on the back of the walkie talkie.
2. Slide the battery pack along the back of the walkie talkie until the release latch on the base of the walkie talkie locks.

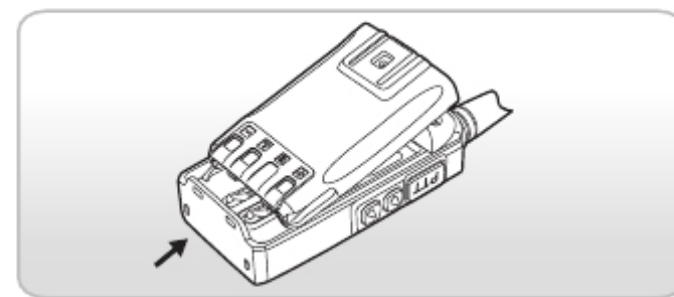

To remove the battery pack, pull down the release latch and slide the battery pack away from the walkie talkie.

## ③ Installing antenna



Screw the antenna into the connector on the top of the walkie talkie by holding the antenna at its base and turning it clockwise until secure.

**NOTE:** The antenna is neither a handle, a key ring retainer, nor a speaker/microphone attachment point. Using the antenna and degrade your walkie talkie's performance.

#### ④ Installing belt clip

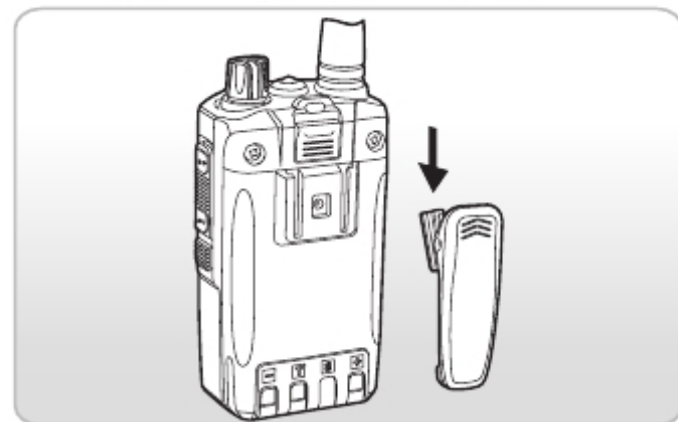

If necessary, you can install the supplied belt clip to the walkie talkie.

#### ⑤ Installing speaker/microphone jacks cover

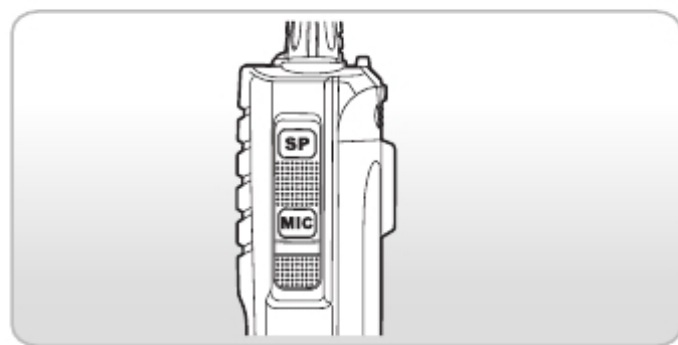

If you are not using a speaker/microphone, install the cover over the speaker/microphone jacks.

**NOTE:**To keep the walkie talkie rainproof, you must install the speaker/microphone cover.

#### ⑥ Installing external speaker/microphone

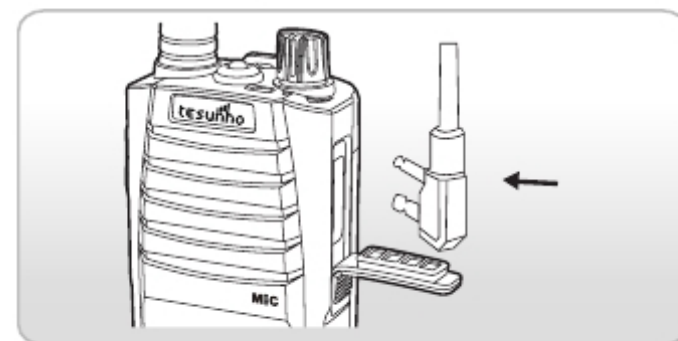

Insert the speaker/microphone plugs into the speaker/microphone jacks.

**NOTE:**The walkie talkie is not fully rainproof while using external speaker/microphone.

## ⑦ Installing UIM card

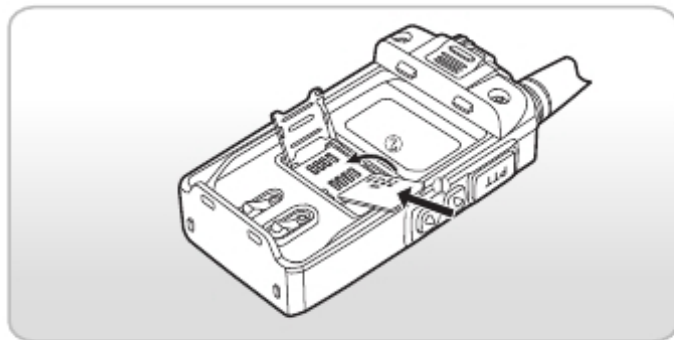

Remove the battery to gain access to the UIM card tray, and then insert the UIM card into its card slot.

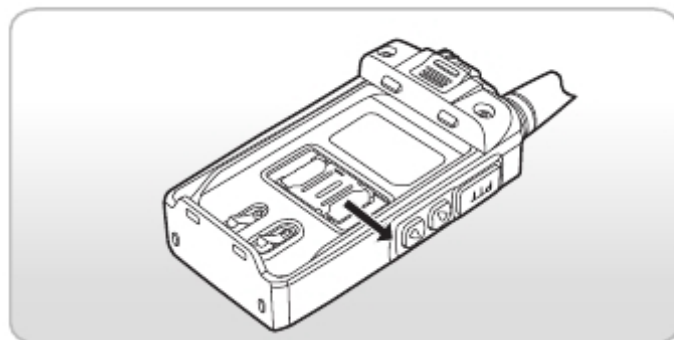

Look for the notched corner, and make sure it matches up with the notch in the tray. The UIM card can be slid out of its holder.

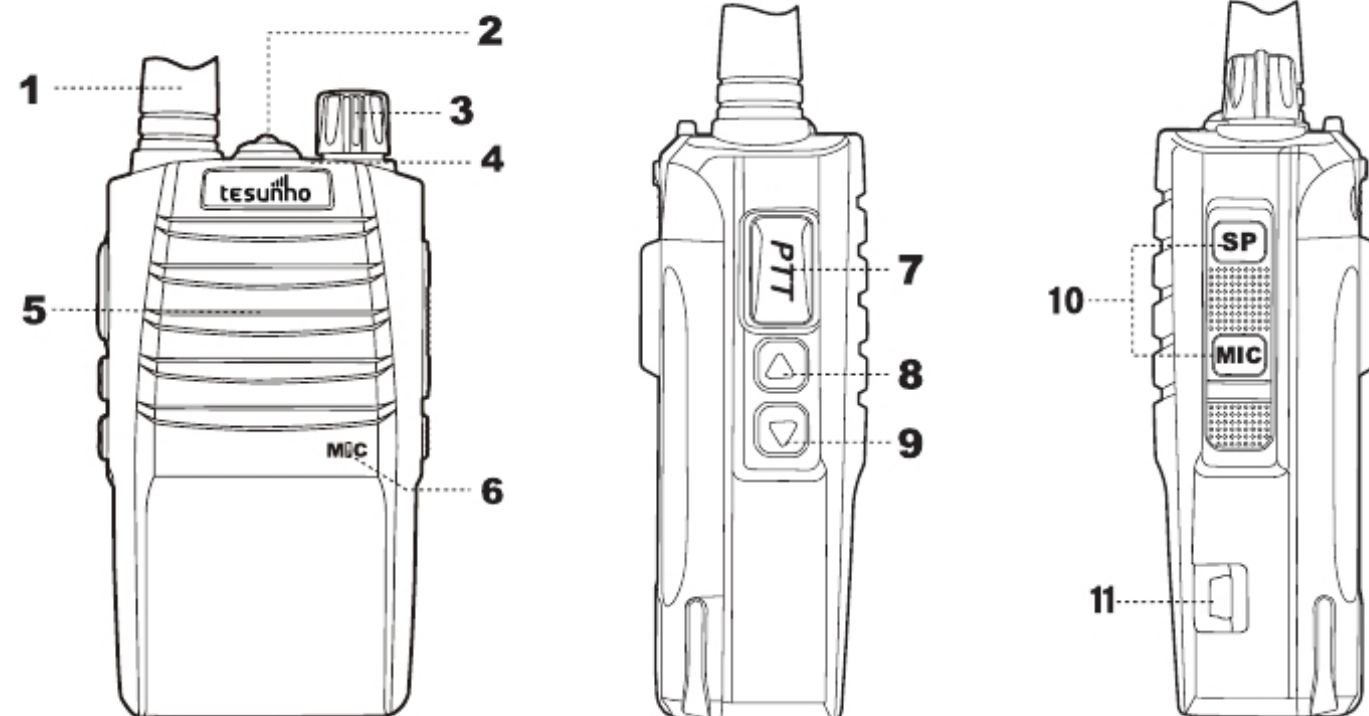

**1. Antenna****2. LED flashlight****3. Power switch/volume control**

- Turn clockwise to switch ON the walkie talkie.
- To switch OFF the walkie talkie , turn counterclockwise until a click sounds.
- Rotate to adjust the volume level.

**4. LED indicator**

- Flashes blue when switching on the walkie talkie.
- Lights red while transmitting.
- Lights blue while receiving a signal.
- Lights purple when pressing and holding PTT key to turn on the walkie talkie.

**5. Speaker****6. Microphone****7. PTT (Push-to-Talk) switch**

- Press PTT key, then speak into the microphone to call a station. Release PTT key to receive.

**8. ▲ Up key**

- Short press----- Select the desired group.
- Long press---- Programmable function key.  
See Page19.

**9. ▼ Down key**

- Short press----- Select the desired group.
- Long press---- Turn ON/OFF LED flashlight.

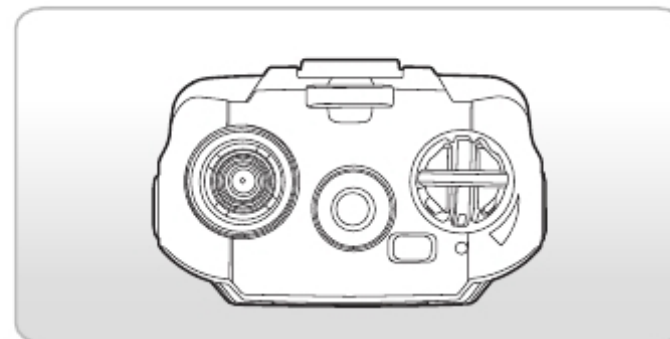
**10. Speaker/Microphone jacks****11. USB jack**

Switch ON the walkie talkie by turning the Power switch/Volume control clockwise.

- Meanwhile, the walkie talkie will sound " Welcome to use digital public network walkie talkie." with the blue light keeping flashing.

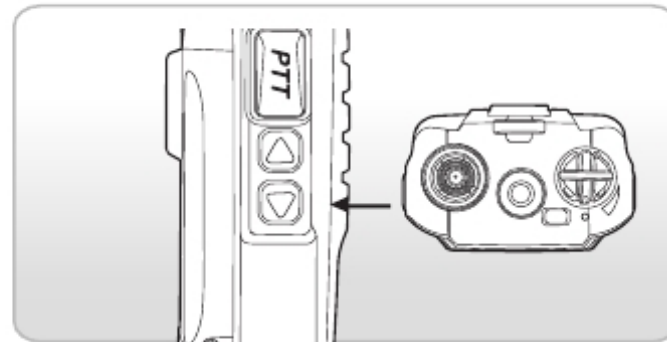

Turn ON / OFF LED flashlight function by long pressing and holding the ▼ key.



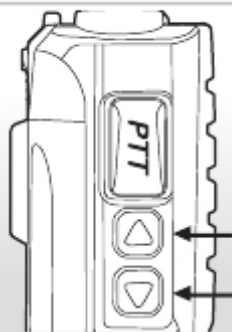

Short press ▲ / ▼ key to select your desired group, you can hear the voice announcement of the selected group.

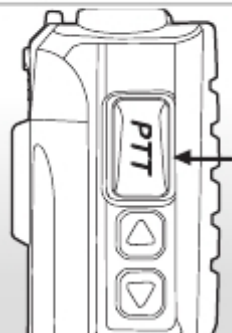

To make a call, press and hold the PTT switch, then speak into the microphone using your normal speaking voice.

- Release the PTT switch to receive.

### 1.Power On

- ① Push up battery buckle, remove the battery, toggle the metal cap of the UIM card slot to the left side, turn up the metal cap and put in the UIM Card, then press the metal cap down tightly and toggle it to the right side in order to tighten the UIM card.
- ② Put the battery in and turn the volume switch clockwise to power on.
- ③ Blue light flashing, voice prompting: Welcome to use the digital public network walkie talkie" "Power Level", "Searching network, please wait".

**NOTE:** There are five power levels: four-fourth battery, three-fourth battery, two-fourth battery, one-fourth battery, and low battery. Four-fourth battery is full battery, the rest levels are decreasing in turn.

- ④ Network searching and voice prompting.

**NOTE:** Network intensity is divided into five levels: excellent network, good network, poor network, poorer network and no network.

⑤ Log in the user's account.

a. Voice prompt: "Log in, please wait", please wait for 20 seconds.

b. After logging in normally, voice prompt: <user name>, " log in successfully", "entering group", <current group name>.

⑥ Get group information.

**NOTE:** If there is the default group, then it will enter the group automatically after power on, and voice prompt the group name.

⑦ Power on completely.

**NOTE:** No blue light means it finished booting. Communication and other operations are available now.

## 2. Transmitting

When you press the PTT button and the red light flashes, it enters transmitting mode and the others will hear you.

If there is an advanced user starts to talk when you are transmitting, you will exit the transmitting

mode and enter the receiving mode. Now you can only receive passively and the other can not hear you. If you keep pressing the PTT button, you will enter the transmitting mode directly after the advanced user finish transmitting.

## 3. Receiving

When the light turns blue means receiving.

It will exit receiving mode when the two following reasons occurs.

a. If the priority of native walkie talkie is higher over the other's priority, it will enter the transmitting mode after pressing the PTT button.

b. It will prompt the group name after pressing the button of group switching. Meanwhile, the talk ends. It will go into the receiving mode again only when the next receiving process, and then it can switch to other groups after pressing the PTT button.

## 4. Group Switching

① Short press ▲ / ▼ key, choose the group you want to use. (It will voice prompt group name every time when you press.)

② Press the PTT button into the group chose. (Voice prompt: "entering the group, <group name>.")

**NOTE:** If the voice prompt does not end, there is no reaction after pressing the PTT button.

You should wait for its ending to enter the group with pressing the PTT button.

### 5. Selective call

① Short press ▲ / ▼ key, choose the group where the one you want to talk alone. Then press the PTT button into the group. (If you want to use the function in current group, you can skip this step.)

② Long press ▲ key, for one second then enter the selective mode. The walkie talkie will prompt "selective mode".

③ Short press ▲ / ▼ key, choose the one you want to talk alone in the group. (It will voice prompt User's name every time when you press.)

④ Press the PTT button to build up the temporary group after confirmation. Then the walkie talkie will prompt "temporary group+ <the counterpart's name>".

⑤ You can start to talk now. If you need to talk with someone in the group alone, you can repeat the above steps.

⑥ After talking, long press ▲ key for one second then it can back to the group. And the walkie talkie will prompt "group call mode".

⑦ Finish selective talking, if there is not talking again after 2 seconds, and not long press ▲ key to back to group, then the walkie talkie will exit "selective group mode" automatically, and then enter "group call mode".

**NOTE:** Only online users can use selective call. Two walkie talkies which is into the selective call mode can talk to each other only. Other group members can not talk with them. If none of the group members is online when you get into the selective call mode, it will prompt "no user in the group" and back to "group call mode" automatically. This function can be used when setting the ▲ key as selective call via the programming software.



### 1. User rights setting

Different user rights will be assigned to all: high level, medium level and low level.

### 2. Interrupt priority

High level user's can interrupt lower level user's talk.

### 3. Definition of programmable function key

Long press ▲ key can make it as the programmable function key.

It can be defined as the following functions:

- ① Battery Status: when it is defined as battery status function, long press ▲ key for 1 second, the walkie talkie will prompt the current battery status, are: "full battery", "three-fourth battery", "two-fourth battery", "one-fourth battery", and "low battery".
- ② Network searching: when it is defined as network searching function, long press ▲ key for 1 second, the walkie talkie will prompt the current network's signal strength, are: "excellent network", "good network", "poor network", "poorer network" and "no network".
- ③ Lock key: when it is set as lock key function, long press ▲ key for 1 second, the walkie talkie will lock ▲ / ▼ key. It will unlock after repeating these steps.
- ④ Selective call: when it is set as selective call function, long press ▲ key for 1 second can enter

the selective call mode, the walkie talkie will prompt "selective call mode".

It will back to the group after repeating these steps and the walkie talkie will prompt "group call mode".

### 4. LED flashlight function

Long press ▼ key to turn ON / OFF LED flashlight.

### 5. Time-out Timer (TOT function)

The purpose of the Time-out Timer is to prevent any single person from using for an extended period time. If you continuously transmit for a long time, the walkie talkie will stop transmitting and a tone will sound. To stop the tone, release the PTT switch. You can press the PTT switch again to resume transmitting.



<b>Problem</b>	<b>Solution</b>
No power.	1.The battery may be dead. Recharge or replace the battery. 2.The battery may not be installed correctly. Remove the battery and install it again.
Battery power dies shortly after charging.	The battery life is finished. Replace the battery with a new one.
Voice prompt "please check if UIM card is installed well".	1.No UIM card installed or Insert UIM card error. 2.The card is set with PIN code.
Voice prompt "not network".	Quick antenna connection check or finetune it. Check the network signal strength, restart the walkie walkie if necessary.
Voice prompt "account or password is wrong" or "account information is not set".	Please contact your authorized <b>tesunho</b> ® dealer to reset the account password.
Voice prompt "please use SMART-PTT company manage platform to enter the group".	Please contact your authorized <b>tesunho</b> ® dealer to reset the account password to reset the group.

## **AFTERSALES SERVICE**

### **Warranty Period**

The warranty period is one year from the date the radio is sold. (It's invalid without the seal of agents.)

### **Free Maintenance**

The seller provides free maintenance for the nature breakups in the warranty period.

### **Paid Maintenance**

Under the following conditions, the seller will charge the maintenance fee:

- When the maintenance is beyond the warranty period, the seller will charge reasonable maintenance fee.
- The breakups are caused by nature disasters.
- The breakups are caused by customers. (or their deliberate intentions.)
- The breakups are caused by the mishandling or operation unpermitted.
- The breakups are caused by using the nonstandard battery packs.

**Agent:**

Ser.No:

Model:

Date:



Quanzhou Fengze Tesunho Electronics Co.,Ltd

NOTE: Features & specifications are subject to change without notice.  
tesunho<sup>®</sup> is not responsible for unintentional for errors or omissions on  
its packaging.